

3.6 AUTOMATIC FANS PARTS LIST AFTER 2009

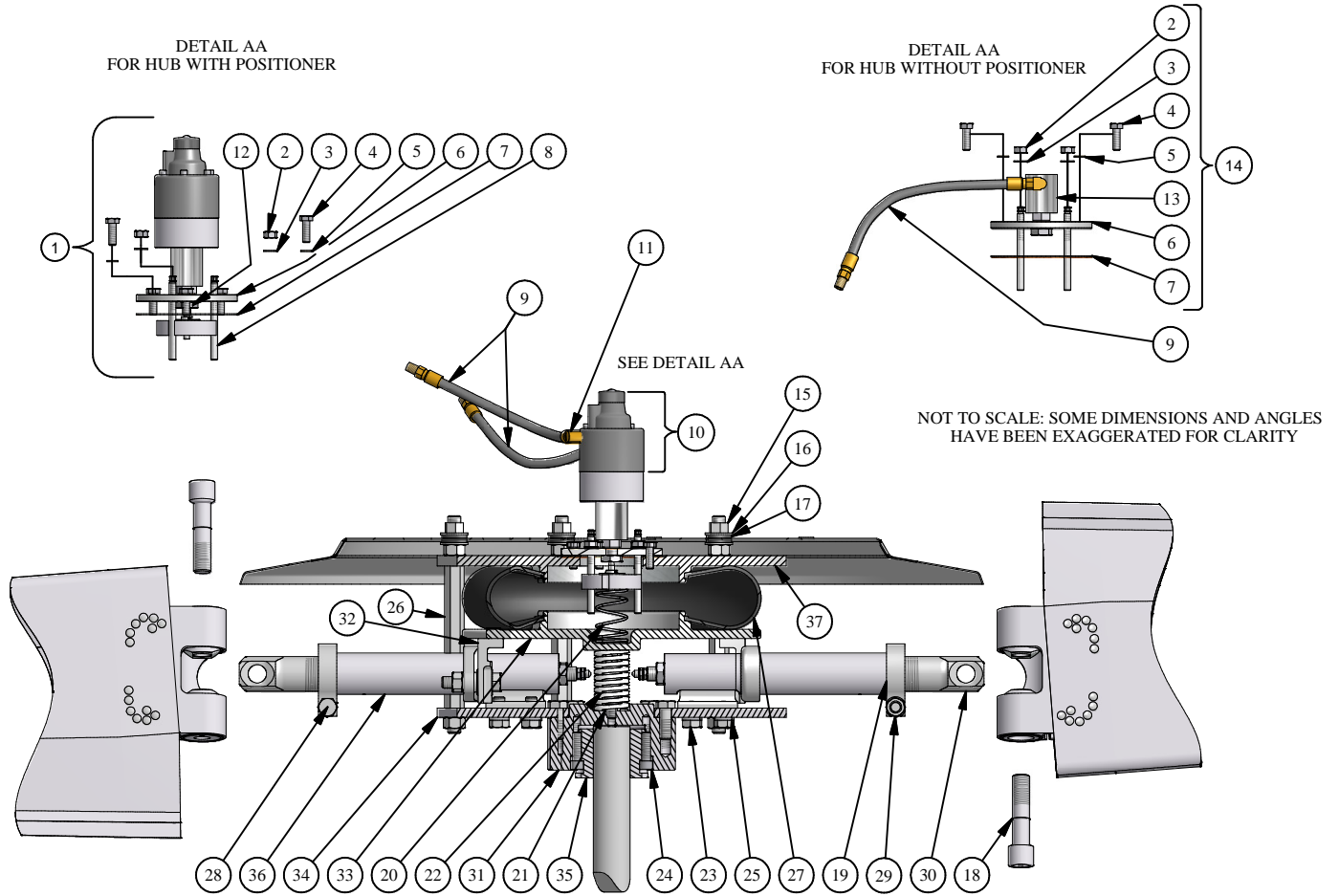

ITEM	PART #	DESCRIPTION
1	2624	CSP UNION ASSEMBLY (WITH POSITIONER)
2	1625	10mm STAINLESS STEEL NUT (3)
3	733	3/8" SEALED WASHER (3)
4	771	10mm x 30mm STAINLESS STEEL BOLT (6)
5	179	3/8" FIBER WASHER (6)
6	162	UNION PLATE
7	163	UNION PLATE GASKET
8	159	STAINLESS STEEL STOP STUD (3)
9	257	12" STANDARD NEOPRENE AIR HOSE ASSEMBLY WITH 1/4" NPT EXTERNAL THREADS BOTH ENDS
10	21	POSITIONER
11	210	1/4" BRASS STREET ELL
12	344	5/8-18 LH LOCKNUT
13	264	CS ROTARY UNION
14	186	CS UNION ASSEMBLY WITH HARDWARE
15	1532	18mm ALUMINUM NUT
16	164	3/4" ALUMINUM FLAT WASHER
17	52	5/8" RESILIENT WASHER
18	2886	24mm x 98mm ALUMINUM BLADE BOLT
19	644	SMALL CLEVIS CLAMP
20		RANGE SPRING
21		RETURN SPRING SHIM

ITEM	PART #	DESCRIPTION
22		RETURN SPRING
23	4515	16mm x 32mm ALUMINUM ANCHOR TEE BOLT (4 per BLADE)
24		12mm HEX BOLT FOR T BUSHING (2) 12mm HEX BOLT FOR U BUSHING (4) 16mm HEX BOLT FOR W BUSHING (4) 16mm HEX BOLT FOR X BUSHING (4)
25	152	5/8" ALUMINUM LOCK WASHER (4 per BLADE)
26	1530	18mm x 302mm ALUMINUM HUB STUD
27	16	DIAPHRAGM ACTUATOR
28	167	16mm x 70mm ALUMINUM BOLT
29	169	16mm ALUMINUM NUT
30	4269	ROD END
31		AUTOMATIC FAN BUSHING ADAPTER
32		PISTON STRUT ASSEMBLY WITH HARDWARE
33		PISTON PLATE
34		AUTOMATIC HUB PLATE
35		T BUSHING (3") U BUSHING (4") W BUSHING (5.5") X BUSHING LONG (5.5")
36		HUB TUBE ASSEMBLY WITH HARDWARE
37		CYLINDER PLATE