

NOTE 1: MAXIMUM FAN DIA. BLADES HORIZONTAL (AS SHIPPED) EQUALS NOMINAL FAN DIA. A ± 1.5" ADJUSTMENT MAY BE MADE DURING INSTALLATION

ROTATION: CLOCKWISE
LOOKING INTO DISCHARGE

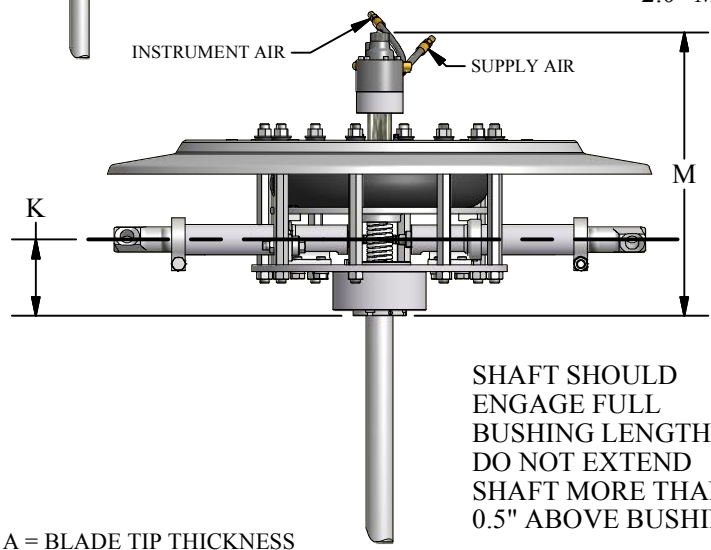
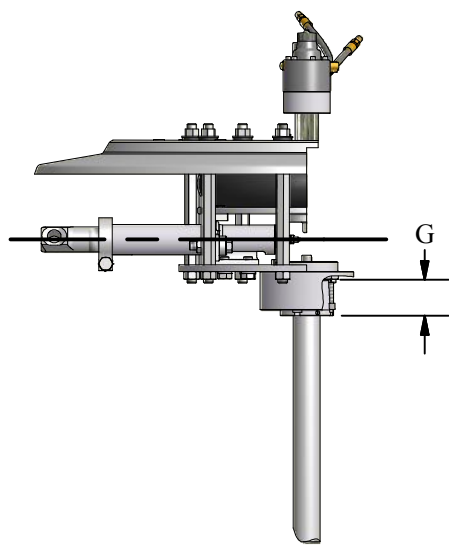
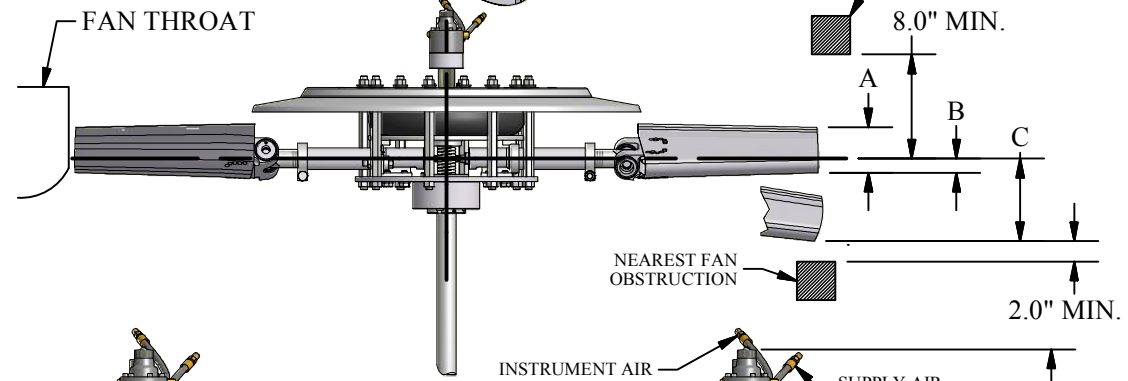

SHAFT SHOULD ENGAGE FULL BUSHING LENGTH. DO NOT EXTEND SHAFT MORE THAN 0.5" ABOVE BUSHING

LETTER DIMENSIONS MAY VARY WITH BLADE ANGLE AND LOADING

WITH FAN OPERATING AT 12000 FT-MINUTE BLADE TIP SPEED
PERCENT BLADE LOADING

| DIA (ft) | A (in.) | PERCENT BLADE LOADING | | C (in.) |
|----------|---------|-----------------------|-----|---------|
| | | 100% | 75% | |
| 5 | 4.8 | 1.4 | 1.0 | 3.4 |
| 6 | 4.4 | 1.7 | 1.2 | 3.7 |
| 7 | 4.0 | 2.0 | 1.5 | 4.0 |
| 8 | 3.6 | 2.4 | 1.8 | 4.4 |
| 9 | 3.2 | 2.8 | 2.1 | 4.8 |
| 10 | 2.8 | 3.2 | 2.4 | 5.2 |

- A = BLADE TIP THICKNESS
- B = RUNNING POSITION OF BLADES
- C = MAXIMUM DROOP POSITION OF BLADES
- G = BUSHING OVERALL HEIGHT
- K = CENTERLINE OF FAN TO BASE OF BUSHING
- # = WITH S.A.E. STANDARD SQUARE KEYWAY
- * = WITH SHALLOW KEYWAY IN BUSHING
- @ = MAX METRIC BORE WITH STANDARD KEYWAY

| MAX BLADES | BUSHING TYPE | MAX. # BORE | MAX. * BORE | MAX. @ BORE | DIM. "G" | DIM. "K" | DIM. "M" |
|------------|--------------|-------------|-------------|-------------|----------|----------|----------|
| 7 | U | 2.75" | 2.938" | 75mm | 2.7" | 5.8" | 21.1" |
| 7 | W | 3.750" | 4.000" | 100mm | 2.8" | 8.7" | 24.1" |
| 7 | X | 3.750" | 4.000" | 100mm | 4.0" | 8.7" | 24.1" |



SERIES 30 CSP AUTOMATIC FAN