

NOTE 1:
 MAXIMUM FAN DIAMETER (BLADES HORIZONTAL - AS SHIPPED) EQUALS NOMINAL FAN DIAMETER. ADJUSTMENT OF ±1.5 INCHES POSSIBLE AT INSTALLATION

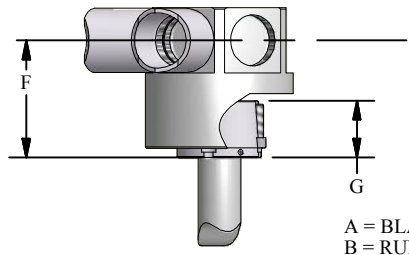

BUSHING CAN BE INSTALLED ON INLET OR OUTLET SIDE OF FAN

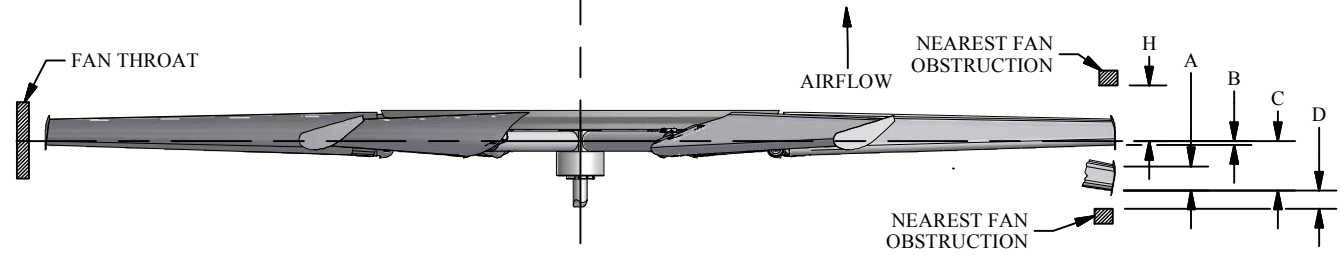
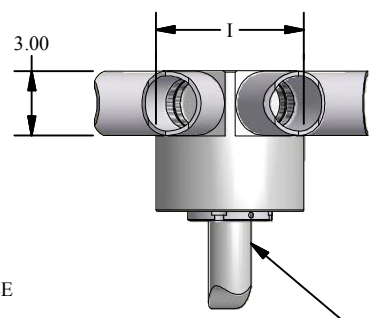

SHAFT (BY OTHERS) MUST FULLY ENGAGE BUSHING

- A = BLADE TIP THICKNESS @ 19° BLADE ANGLE
- B = RUNNING POSITION OF BLADES
- C = MAXIMUM DROOP POSITION OF BLADES
- D = MINIMUM OBSTACLE CLEARANCE AT INLET
- F = CENTERLINE OF FAN TO BASE OF BUSHING
- G = BUSHING OVERALL HEIGHT
- H = MINIMUM OBSTACLE CLEARANCE AT OUTLET
- I = NOMINAL MECHANICAL HUB DIAMETER
- L = MAX. BUSHING TORQUE FT. LBS.
- # = WITH S.A.E. STANDARD SQUARE KEYWAY
- * = WITH SHALLOW KEYWAY IN BUSHING
- ° = MAX METRIC BORE WITH STANDARD KEYWAY

WITH FAN OPERATING AT 12000 FT: MINUTE BLADE TIP SPEED PERCENT BLADE LOADING

DIA	PERCENT BLADE LOADING		C	D	H	
	100%	75%				
10'	1.9"	3.0"	2.5"	4.0"	2.0"	7.0"
11'	1.7"	3.7"	3.0"	5.0"	2.0"	7.0"
12'	1.6"	4.4"	3.6"	6.2"	2.0"	7.0"
13'	1.5"	5.3"	4.2"	7.5"	2.0"	7.0"
14'	1.4"	6.2"	4.9"	8.8"	2.0"	7.0"
15'	1.2"	7.2"	5.6"	10.3"	2.0"	7.0"
16'	1.1"	8.3"	6.4"	12.0"	2.0"	7.0"
17'	1.0"	9.5"	7.4"	13.8"	2.0"	7.0"
18'	1.0"	10.8"	8.4"	15.7"	2.0"	7.0"
19'	0.9"	12.2"	9.4"	17.8"	2.0"	7.0"
20'	0.8"	13.8"	10.6"	20.1"	2.0"	7.0"

MAX BLADES	BUSHING TYPE	MAX # BORE	MAX * BORE	MAX ° BORE	I	F	G	L
6	U	2.750"	2.938"	75	7"	8.0" OR 12"	2.7"	4000
8	U	2.750"	2.938"	75	9"	8.0" OR 12"	2.7"	4000
12	U	2.750"	2.938"	75	12"	8.0" OR 12"	2.7"	4000
8	W	3.750"	4.000"	100	9"	8.0" OR 12"	2.8"	7300
12	W	3.750"	4.000"	100	12"	8.0" OR 12"	2.8"	7300
8	X	3.750"	4.000"	100	9"	8.0" OR 12"	4.0"	9800
12	X	3.750"	4.000"	100	12"	8.0" OR 12"	4.0"	9800
12	Z	5.000"	5.500"	140	12"	8.0" OR 12"	4.0"	18000



SERIES 60 EXTENDED HUB HD FAN RIGHT HAND ROTATION