

NOTE 1:
MAXIMUM FAN DIAMETER (BLADES
HORIZONTAL - AS SHIPPED) EQUALS
NOMINAL FAN DIAMETER. ADJUSTMENT
OF ±1.5 INCHES* POSSIBLE AT
INSTALLATION

*BLADES WITH ATEX TIPS
HAVE ADJUSTMENT OF -1.0"
& +2.0 ON DIAMETER"

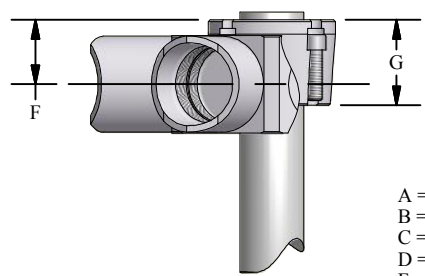

BUSHING AND/OR AIR SEAL
CAN BE INSTALLED ON INLET
OR OUTLET SIDE OF FAN

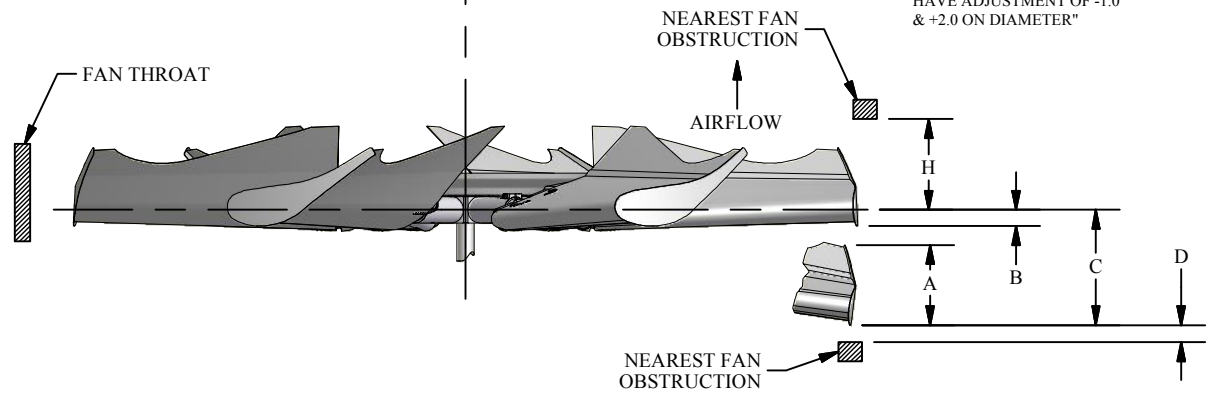
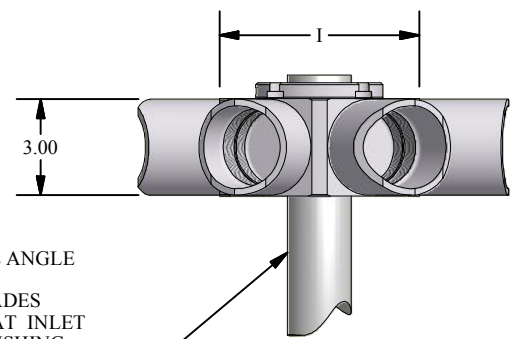

SHAFT (BY OTHERS) MUST
FULLY ENGAGE BUSHING

- A = BLADE TIP THICKNESS @ 19° BLADE ANGLE
- B = RUNNING POSITION OF BLADES
- C = MAXIMUM DROOP POSITION OF BLADES
- D = MINIMUM OBSTACLE CLEARANCE AT INLET
- F = CENTERLINE OF FAN TO BASE OF BUSHING
- G = BUSHING OVERALL HEIGHT
- H = MINIMUM OBSTACLE CLEARANCE AT OUTLET
- I = NOMINAL MECHANICAL HUB DIAMETER
- L = MAX. BUSHING TORQUE FT. LBS.
- # = WITH S.A.E. STANDARD SQUARE KEYWAY
- * = WITH SHALLOW KEYWAY IN BUSHING
- ° = MAX METRIC BORE WITH STANDARD KEYWAY

WITH FAN OPERATING
AT 12000 FT. MINUTE
BLADE TIP SPEED
PERCENT BLADE
LOADING

DIA	100%		75%		C	D	H
	A	B	B	C			
5'	7.5"	4.3"	4.3"	4.6"	2.0"	14.0"	
6'	7.5"	4.7"	4.5"	5.2"	2.0"	14.0"	
7'	7.5"	5.2"	4.9"	6.0"	2.0"	14.0"	
8'	7.5"	5.9"	5.4"	7.0"	2.0"	14.0"	
9'	7.5"	6.7"	6.0"	8.3"	2.0"	14.0"	
10'	7.5"	7.6"	6.8"	9.8"	2.0"	14.0"	

MAX BLADES	BUSHING TYPE	MAX # BORE	MAX * BORE	MAX ° BORE	I	F	G	L
6	U	2.750"	2.938"	75	7"	2.0"	2.7"	4000
7	U	2.750"	2.938"	75	9"	2.0"	2.7"	4000
7	W	3.750"	4.000"	100	9"	2.2"	2.8"	7300
7	X	3.750"	4.000"	100	9"	2.2"	4.0"	9800



SERIES 30 STANDARD HUB EXTENDED CHORD HD FAN-RIGHT HAND ROTATION