

NOTE 1:  
 MAXIMUM FAN DIAMETER (BLADES HORIZONTAL - AS SHIPPED) EQUALS NOMINAL FAN DIAMETER. ADJUSTMENT OF -.5 INCHES ON DIAMETER\* POSSIBLE AT INSTALLATION

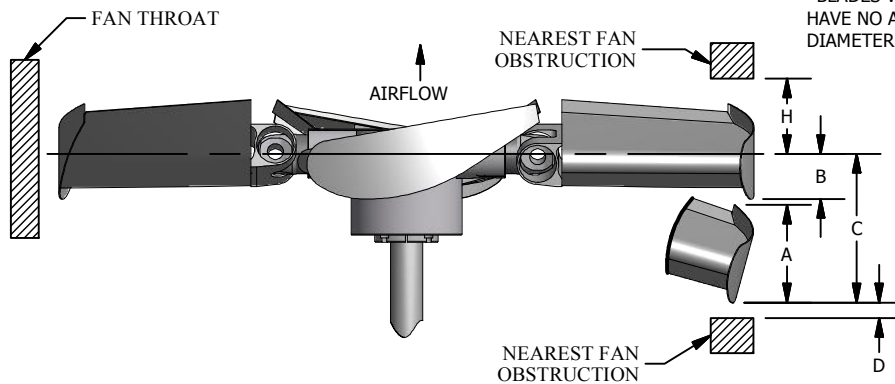

\*BLADES WITH ATEX TIPS HAVE NO ADJUSTMENT ON DIAMETER

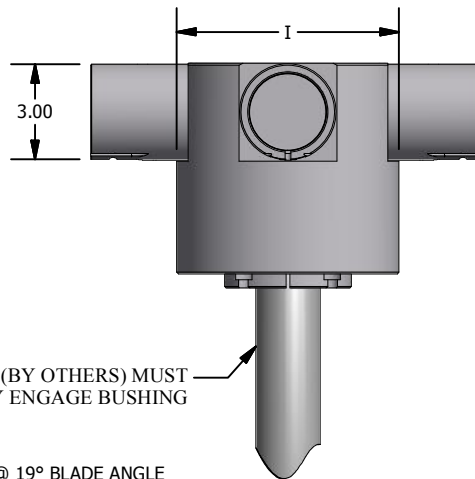
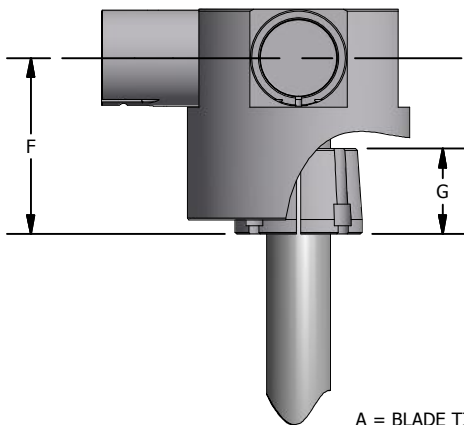

SHAFT (BY OTHERS) MUST FULLY ENGAGE BUSHING

- A = BLADE TIP THICKNESS @ 19° BLADE ANGLE
- B = RUNNING POSITION OF BLADES
- C = MAXIMUM DROOP POSITION OF BLADES
- D = MINIMUM OBSTACLE CLEARANCE AT INLET
- F = CENTERLINE OF FAN TO BASE OF BUSHING
- G = BUSHING OVERALL HEIGHT
- H = MINIMUM OBSTACLE CLEARANCE AT OUTLET
- I = NOMINAL MECHANICAL HUB DIAMETER
- L = MAX. BUSHING TORQUE FT. LBS.
- # = WITH S.A.E. STANDARD SQUARE KEYWAY
- \* = WITH SHALLOW KEYWAY IN BUSHING
- ° = MAX METRIC BORE WITH STANDARD KEYWAY

WITH FAN OPERATING AT 12000 FT: MINUTE BLADE TIP SPEED  
 PERCENT BLADE LOADING

DIA	A	B		C	D	H
		100%	75%			
3'	5.2"	1.1"	0.8"	3.1"	2.0"	7.0"
4'	4.8"	1.4"	1.0"	3.4"	2.0"	7.0"
5'	4.4"	1.7"	1.3"	3.7"	2.0"	7.0"
6'	4.0"	2.0"	1.5"	4.0"	2.0"	7.0"

MAX BLADES	BUSHING TYPE	MAX # BORE	MAX * BORE	MAX ° BORE	I	F	G	L
6	U	2.750"	2.938"	75	7"	8.0" OR 12"	2.7"	4000



## SERIES 18 EXTENDED HUB HD FAN RIGHT HAND ROTATION