

- A = BLADE TIP THICKNESS @ 19° BLADE ANGLE
- B = RUNNING POSITION OF BLADES
- C = MAXIMUM DROOP POSITION OF BLADES
- D = MINIMUM OBSTACLE CLEARANCE AT INLET
- F = CENTERLINE OF FAN TO BASE OF BUSHING
- G = BUSHING OVERALL HEIGHT
- H = MINIMUM OBSTACLE CLEARANCE AT OUTLET
- I = NOMINAL MECHANICAL HUB DIAMETER
- L = MAX . BUSHING TORQUE FT. LBS.
- # = WITH S.A.E. STANDARD SQUARE KEYWAY
- \* = WITH SHALLOW KEYWAY IN BUSHING
- ° = MAX METRIC BORE WITH STANDARD KEYWAY

WITH FAN OPERATING  
AT 12000 FT:MINUTE  
BLADE TIP SPEED  
PERCENT BLADE  
LOADING

	100%	75%
--	------	-----

DIA	A	B	C	D	H
9.5'	21.5"	14.0" 13.0"	16.0"	6"	23.1"

NUMBER OF BLADES	BUSHING TYPE	MAX # BORE	MAX * BORE	MAX ° BORE	I	F	G	L
3,4,5	W	3.75"	4.00"	100 12"		2.9"	2.8"	7300



## SERIES 30 HD MAG LEFT HAND ROTATION

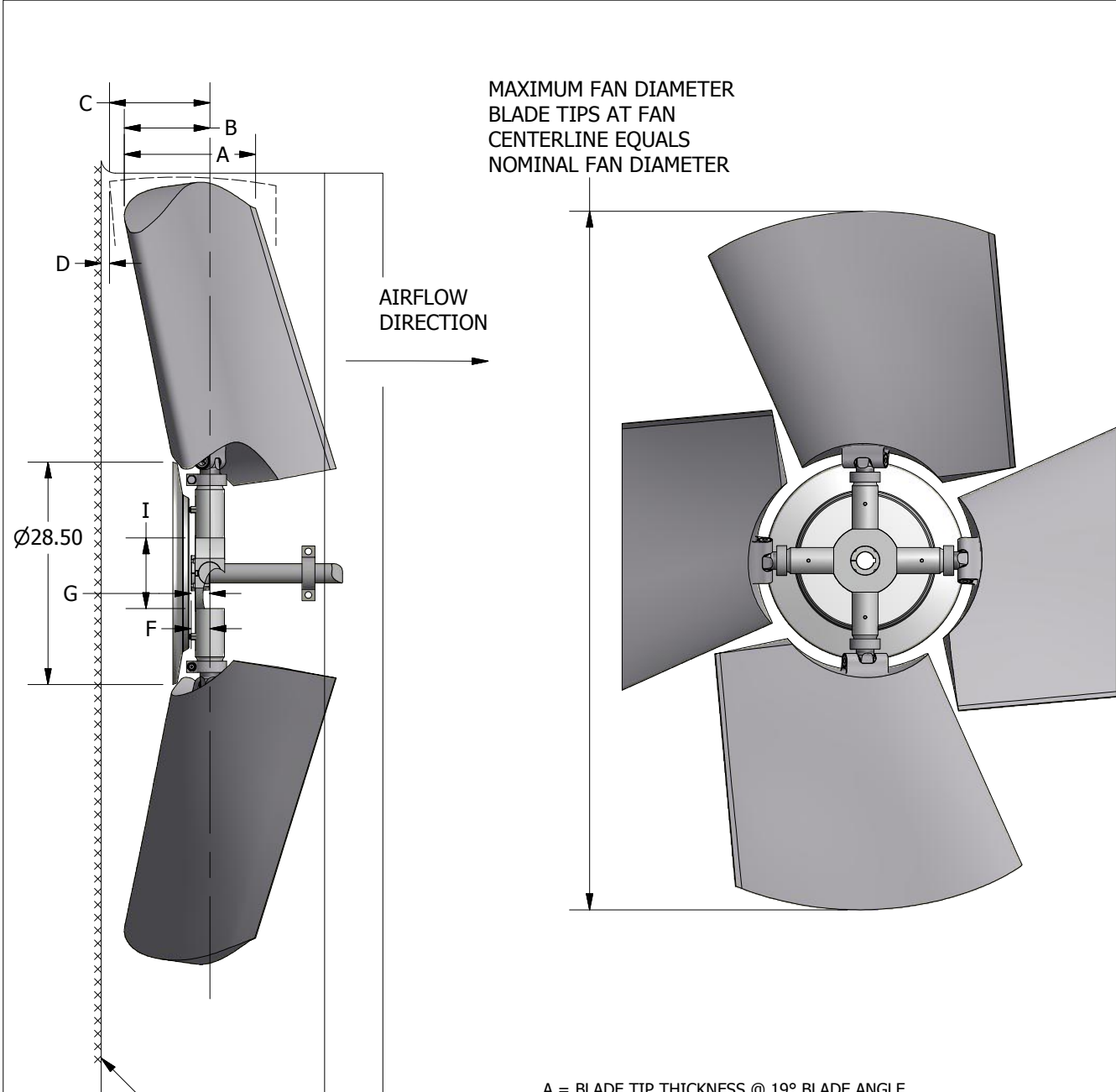

- A = BLADE TIP THICKNESS @ 19° BLADE ANGLE
- B = RUNNING POSITION OF BLADES
- C = MAXIMUM DROOP POSITION OF BLADES
- D = MINIMUM OBSTACLE CLEARANCE AT INLET
- F = CENTERLINE OF FAN TO BASE OF BUSHING
- G = BUSHING OVERALL HEIGHT
- H = MINIMUM OBSTACLE CLEARANCE AT OUTLET
- I = NOMINAL MECHANICAL HUB DIAMETER
- L = MAX . BUSHING TORQUE FT. LBS.
- # = WITH S.A.E. STANDARD SQUARE KEYWAY
- \* = WITH SHALLOW KEYWAY IN BUSHING
- ° = MAX METRIC BORE WITH STANDARD KEYWAY

WITH FAN OPERATING  
AT 12000 FT:MINUTE  
BLADE TIP SPEED  
PERCENT BLADE  
LOADING

DIA	A	100% 75%		C	D	H
		B	B			
9.5'	21.5"	14.0"	13.0"	16.0"	6"	23.1"

NUMBER OF BLADES	BUSHING TYPE	MAX # BORE	MAX * BORE	MAX ° BORE	I	F	G	L
3,4,5	W	3.75"	4.00"	100	12"	2.9"	2.8"	7300



## SERIES 30 HD MAG LEFT HAND ROTATION