

CLASS 10000 HD SERIES 60 FRP

FIBER REINFORCED POLYMER, RH ROTATION

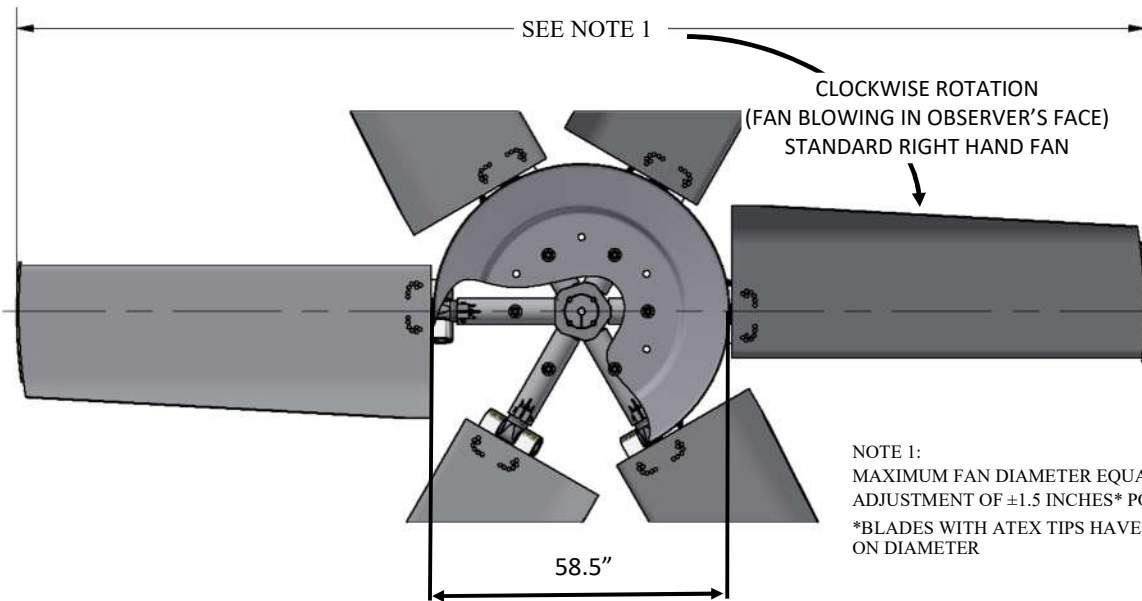

NOTE 1:
 MAXIMUM FAN DIAMETER EQUALS NOMINAL FAN DIAMETER.
 ADJUSTMENT OF ±1.5 INCHES* POSSIBLE AT INSTALLATION
 *BLADES WITH ATEX TIPS HAVE ADJUSTMENT OF -1.0" & +2.0" ON DIAMETER

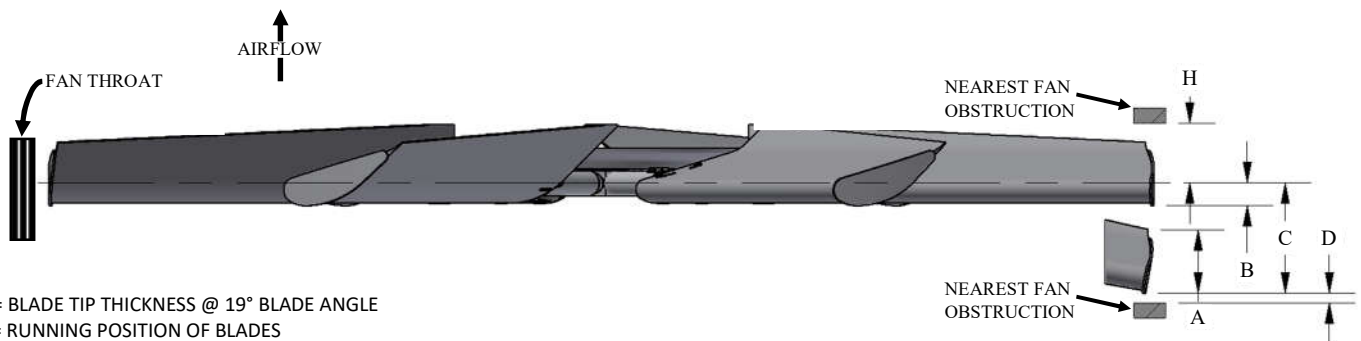

- A = BLADE TIP THICKNESS @ 19° BLADE ANGLE
- B = RUNNING POSITION OF BLADES
- C = MAXIMUM DROOP POSITION OF BLADES
- D = MINIMUM OBSTACLE CLEARANCE AT INLET
- F = CENTERLINE OF FAN TO BASE OF BUSHING
- G = BUSHING OVERALL HEIGHT
- H = MINIMUM OBSTACLE CLEARANCE AT OUTLET
- I = NOMINAL MECHANICAL HUB DIAMETER
- L = MAXIMUM BUSHING TORQUE FT. LBS.
- # = WITH S.A.E. STANDARD SQUARE KEYWAY
- * = WITH SHALLOW KEYWAY IN BUSHING
- ∅ = MAX METRIC BORE WITH STANDARD KEYWAY

BUSHING AND/OR AIR SEAL
 CAN BE INSTALLED ON INLET

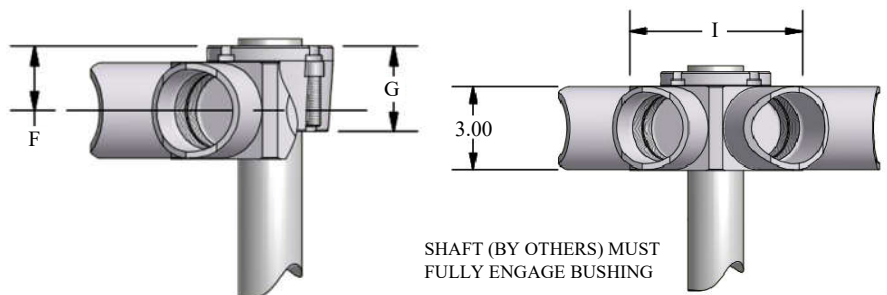

WITH FAN OPERATING AT
 12000 FT/MINUTE BLADE TIP SPEED

PERCENT BLADE
 LOADING
 100% 75%

DIA	A	B		C	D	H
		100%	75%			
10'	8.4"	5.1"	4.9"	5.5"	2.0"	14.0"
11'	8.4"	5.5"	5.2"	6.1"	2.0"	14.0"
12'	8.4"	6.0"	5.6"	6.7"	2.0"	14.0"
13'	8.4"	6.5"	6.0"	7.5"	2.0"	14.0"
14'	8.4"	7.1"	6.4"	8.3"	2.0"	14.0"
15'	8.4"	7.7"	6.9"	9.2"	2.0"	14.0"
16'	8.4"	8.4"	7.5"	10.2"	2.0"	14.0"
17'	8.4"	9.1"	8.1"	11.2"	2.0"	14.0"
18'	8.4"	9.9"	8.7"	12.4"	2.0"	14.0"

MAX BLADES	BUSHING TYPE	MAX # BORE	MAX * BORE	MAX ∅ BORE	I	F	G	L
8	U	2.750"	2.938"	75	9"	2.0"	2.7"	4000
12	U	2.750"	2.938"	75	12"	2.0"	2.7"	4000
8	W	3.750"	4.000"	100	9"	2.2"	2.8"	7300
12	W	3.750"	4.000"	100	12"	2.2"	2.8"	7300
12	Z	5.000"	5.500"	140	12"	2.2"	4.0"	18000