

SEE NOTE 1

CLOCKWISE ROTATION
(FAN BLOWING IN OBSERVER'S FACE)
STANDARD RIGHT HAND FAN

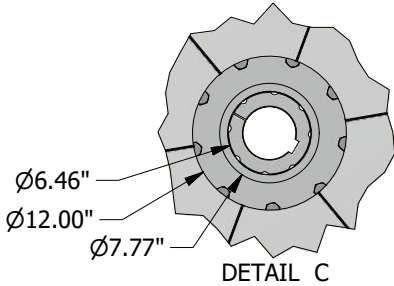
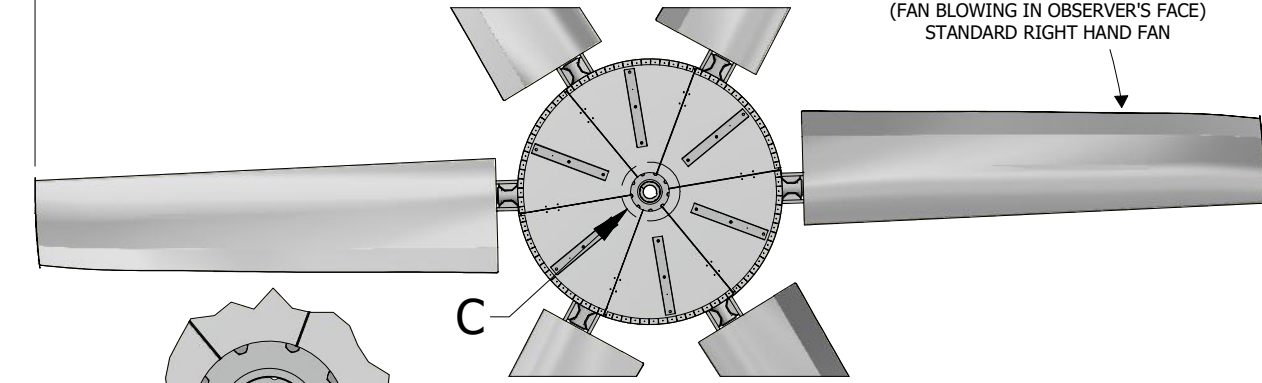

DETAIL C

HUB/BUSHING DETAIL

NOTE 1:
MAXIMUM FAN DIAMETER (BLADES HORIZONTAL - AS SHIPPED) EQUALS NOMINAL FAN DIAMETER. ADJUSTMENT OF ± 1.5 INCHES POSSIBLE AT INSTALLATION.

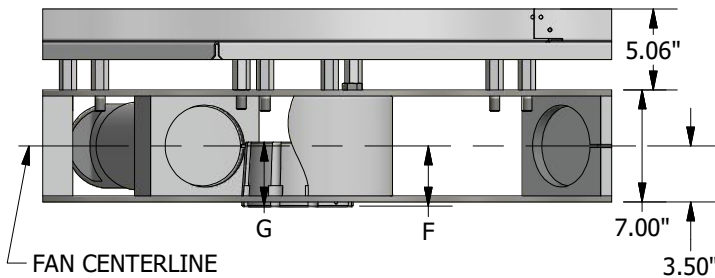

FAN CENTERLINE

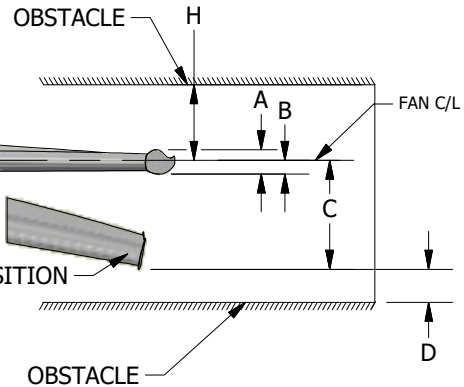

- A = BLADE TIP THICKNESS @ 8° BLADE TIP ANGLE
- B = RUNNING POSITION OF BLADES
- C = MAXIMUM DROOP POSITION OF BLADES
- D = MINIMUM OBSTACLE CLEARANCE AT INLET
- H = MINIMUM OBSTACLE CLEARANCE AT OUTLET

BLADE MAX DROOP POSITION

DIA	PERCENT BLADE LOADING		C	D	H	
	BLADE ANGLE	100%				75%
		8°				
28.0'	7.5"	2.6"	2.0"	3.8"	15.0"	20.0"
29.0'	7.5"	3.2"	2.4"	4.7"	15.0"	20.0"
30.0'	7.5"	3.9"	3.0"	5.7"	15.0"	20.0"
31.0'	7.5"	4.6"	3.6"	6.8"	15.0"	20.0"
32.0'	7.5"	5.5"	4.2"	8.1"	15.0"	20.0"
33.0'	7.5"	6.5"	5.0"	9.6"	15.0"	20.0"
34.0'	7.5"	7.6"	5.8"	11.2"	15.0"	20.0"
35.0'	7.5"	8.9"	6.8"	13.1"	15.0"	20.0"
36.0'	7.5"	10.2"	7.8"	15.1"	15.0"	20.0"

- F = CENTERLINE OF FAN TO BASE OF BUSHING
- G = BUSHING OVERALL HEIGHT
- L = MAX. BUSHING TORQUE FT. LBS.
- # = WITH S.A.E. STANDARD SQUARE KEYWAY
- * = WITH SHALLOW KEYWAY IN BUSHING
- o = MAX. METRIC BORE WITH STANDARD KEYWAY

BUSHING TYPE	MAX BLADES	MAX # BORE	MAX * BORE	MAX o BORE	F	G	L
Z	12	5.000"	5.500"	140	3.7"	4.0"	18000



SERIES 120 STANDARD HUB HD FAN RIGHT HAND ROTATION