

NOTE 1:
 MAXIMUM FAN DIAMETER (BLADES HORIZONTAL - AS SHIPPED) EQUALS NOMINAL FAN DIAMETER. ADJUSTMENT OF ±1.5 INCHES POSSIBLE AT INSTALLATION.

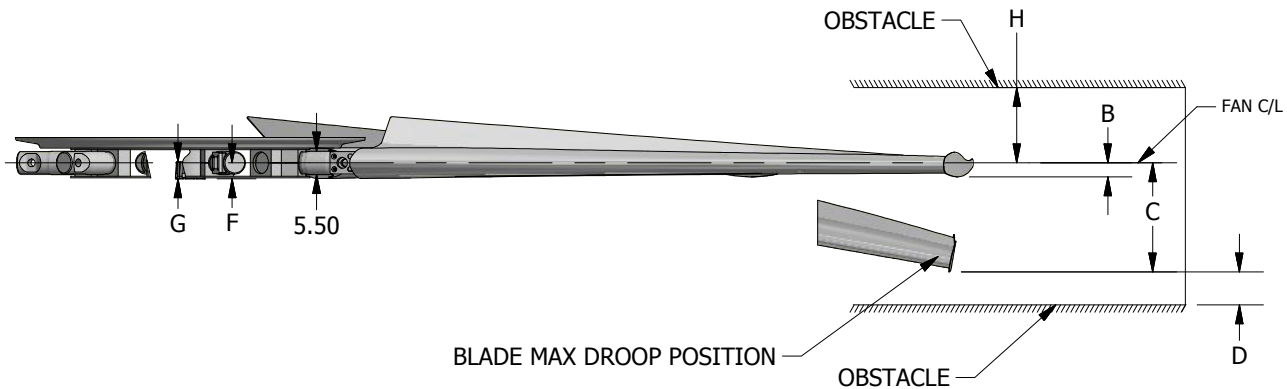

- A = BLADE TIP THICKNESS @ 8° BLADE TIP ANGLE
- B = RUNNING POSITION OF BLADES
- C = MAXIMUM DROOP POSITION OF BLADES
- D = MINIMUM OBSTACLE CLEARANCE AT INLET
- H = MINIMUM OBSTACLE CLEARANCE AT OUTLET

- F = CENTERLINE OF FAN TO BASE OF BUSHING
- G = BUSHING OVERALL HEIGHT
- L = MAX. BUSHING TORQUE FT. LBS.
- # = WITH S.A.E. STANDARD SQUARE KEYWAY
- * = WITH SHALLOW KEYWAY IN BUSHING
- ° = MAX. METRIC BORE WITH STANDARD KEYWAY

DIA	BLADE ANGLE	PERCENT BLADE LOADING		C	D	H
		100%	75%			
	8°					
24.0'	7.5"	1.9"	1.5"	2.8"	15.0"	20.0"
25.0'	7.5"	2.4"	1.8"	3.5"	15.0"	20.0"
26.0'	7.5"	2.9"	2.3"	4.3"	15.0"	20.0"
27.0'	7.5"	3.6"	2.7"	5.2"	15.0"	20.0"
28.0'	7.5"	4.3"	3.3"	6.2"	15.0"	20.0"
29.0'	7.5"	5.1"	3.9"	7.4"	15.0"	20.0"

BUSHING TYPE	MAX BLADES	MAX # BORE	MAX * BORE	MAX ° BORE	F	G	L
					Z	12	5.000"



SERIES 72 STANDARD HUB HD FAN RIGHT HAND ROTATION