

NOTE 1: MAXIMUM FAN DIAMETER (BLADES HORIZONTAL - AS SHIPPED) EQUALS NOMINAL FAN DIAMETER. ADJUSTMENT OF ± 1.5 INCHES POSSIBLE AT INSTALLATION

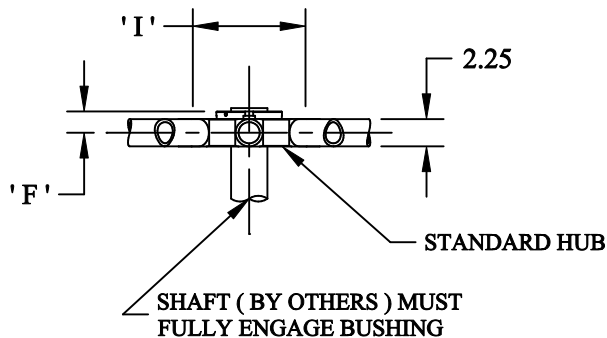
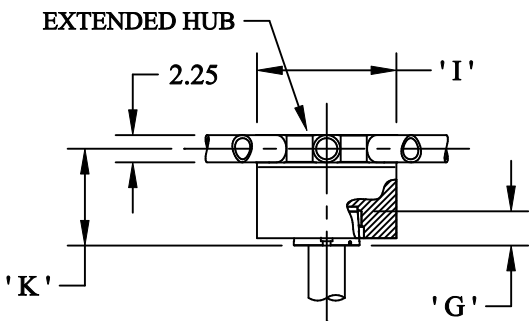
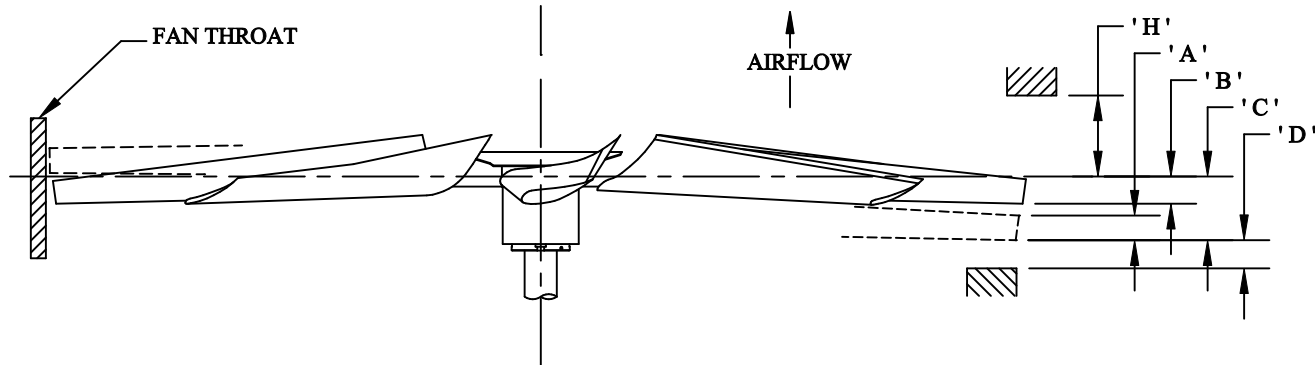

- A = BLADE TIP THICKNESS @ 19° BLADE ANGLE
- B = RUNNING POSITION OF BLADES
- C = MAXIMUM DROOP POSITION OF BLADES
- D = MINIMUM OBSTACLE CLEARANCE AT INLET
- F = CENTERLINE OF FAN TO BASE OF BUSHING (STANDARD HUB)
- G = BUSHING OVERALL HEIGHT (STANDARD & EXTENDED HUBS)
- H = MINIMUM OBSTACLE CLEARANCE AT OUTLET
- I = NOMINAL MECHANICAL HUB DIAMETER
- K = CENTERLINE OF FAN TO BASE OF BUSHING (EXTENDED HUB)
- # = WITH S.A.E. STANDARD SQUARE KEYWAY
- * = WITH SHALLOW KEYWAY IN BUSHING

WITH FAN OPERATING
AT 12000 FT : MINUTE
BLADE TIP SPEED
PERCENT BLADE
LOADING

DIA	100%		75%		C	D	H	MAX BLADES	BUSHING TYPE	MAX # BORE	MAX * BORE	I	F	G	K
	A	B	A	B											
4'	5.0"	1.2"	0.9"	3.2"	2.0"	7.0"						6"	1.3"	1.9"	
5'	4.6"	1.5"	1.1"	3.5"	2.0"	7.0"	6	T	2.000	2.188		7"	1.6"	2.7"	8" OR 12"
6'	4.2"	1.8"	1.4"	3.8"	2.0"	7.0"	6	U	2.750	2.938					

SERIES 24 SD FAN RIGHT HAND ROTATION

