



---

# PARTS LIST

MODEL 5400 FANS

## Contents

6.1 AUTOMATIC FANS: SERIES 33-60 3-8 BLADES .....	2
6.2 AUTOMATIC FANS: SERIES 49-73 9-12 BLADES .....	3
6.3 MANUAL FANS .....	4
6.4 SERIES 19 PARTS LIST .....	5

# 6.1 AUTOMATIC FANS: SERIES 33-60 3-8 BLADES

## HUB TYPES CS AND CSP

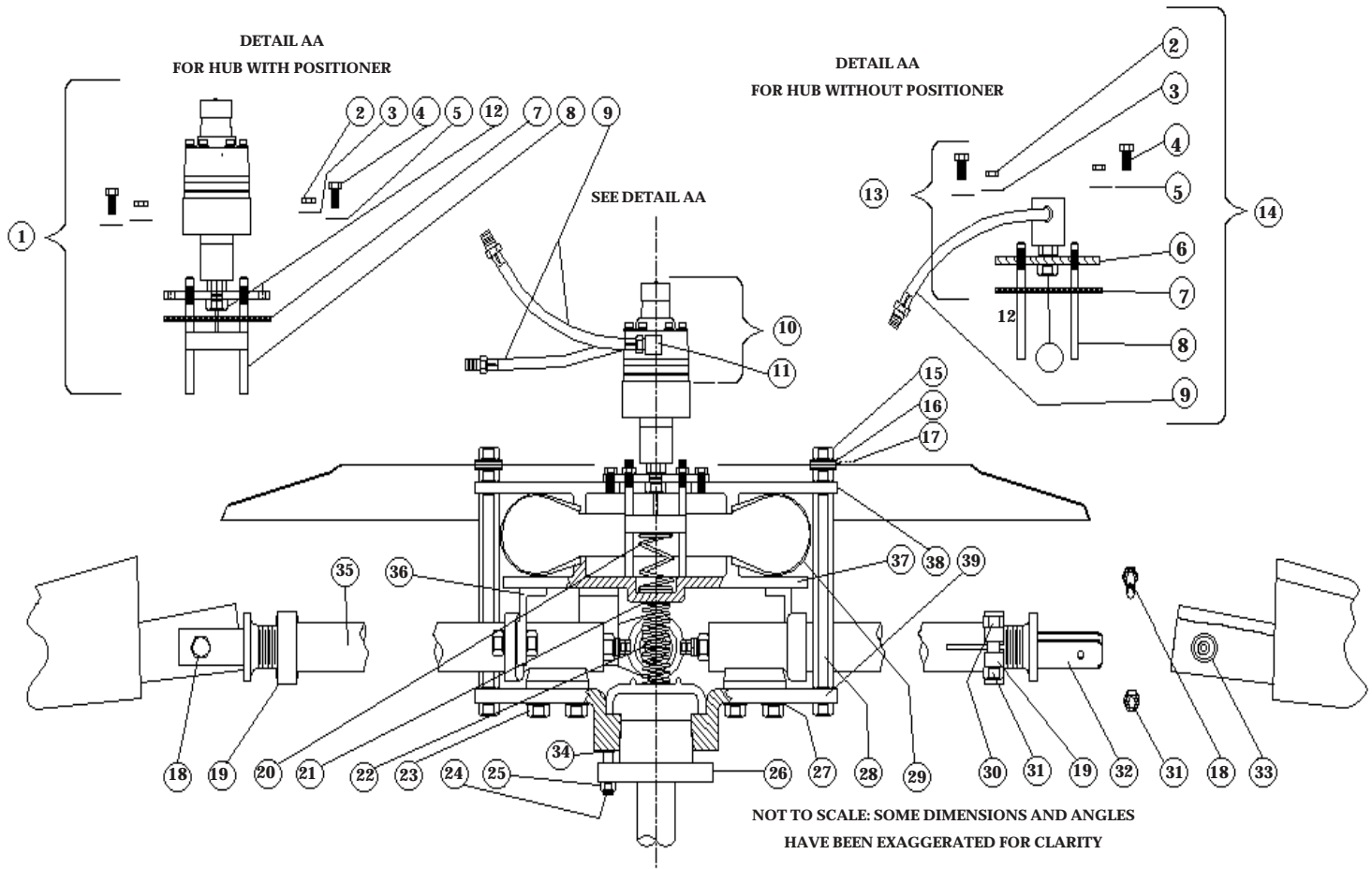

SHOP DWG. NO.	DWG. NO.	DESCRIPTION
1	2624	CSP UNION ASSEMBLY WITH POSITIONER
2	1626	10 MM STAINLESS STEEL NUT (3)
3	733	3/8"SEALED WASHER (3)
4	771	10 MM X 30 MM STAINLESS BOLT (6)
5	179	3/8" FIBER WASHER (6)
6	162	UNION PLATE
7	163	UNION PLATE GASKET
8	159	STAINLESS STEEL STOP STUD (3)
9	257	12' STANDARD STAINLESS STEEL AIRHOSE ASSEMBLY WITH 1/4" NPT EXTERNAL THREADS BOTH ENDS
10	21	POSITIONER
11	210	1/4" BRASS STREET ELL
12	344	5/8-18 LH LOCKNUT
13	264	CS ROTARY UNION
14	186	CS UNION ASSEMBLY WITH HARDWARE
15	1532	18 MM ALUMINUM HEX NUT
16	104	3/4" ALUMINUM FLAT WASHER
17	52	5/8" RESILIENT WASHER
18	168	16 MM X 108 MM ALUMINUM CLEVIS/BLADE BOLT
19	644	SMALL CLEVIS CLAMP
20		RANGE SPRING
21		RETURN SPRING SHIM
22		RETURNSPRING

SHOP DWG. NO.	DWG. NO.	DESCRIPTION
23	1515	16MM X 32 MM ALUMINUM ANCHOR TEE BOLT (4/BLADE)*
24	1345	10MM S S STUD FOR QDSF BUSHING (3)
	1347	12 MM S S STUD FOR QDE BUSHING (3)
25	1346	10 MM S S NUT FOR QDSF BUSHING (3)
	1348	12 MM S S NUT FOR QDE BUSHING (3)
26		QDSF OR QDE TYPE BUSHING
27	152	5/8" ALUMINUM LOCK WASHER (4/BLADE)*
28	1630	18 MM X 302 MM ALUMINUM HUB STUD
29	16	DIAPHRAGM ACTUATOR
30	167	16 MM X 70 MM ALUMINUM BOLT (FOR CLEVIS CLAMP)
31	169	16 MM ALUMINUM NUT
32	2252	CLEVIS
33	637	SMALL MOUNT (1,436")
	989	LARGE MOUNT (1,744")**
34		BUSHING STUD WASHER
35		HUB TUBE ASSEMBLY WITH HARDWARE
36		PISTON STRUT ASSEMBLY WITH HARDWARE
37		PISTON PLATE
38		CYLINDER PLATE
39		HUB PLATE

\* 2/BLADE FOR SERIES 33

\*\* NOT AVAILABLE ON SERIES 33 OR 40

## 6.2 AUTOMATIC FANS: SERIES 49-73 9-12 BLADES HUB TYPES CSJ AND CSPJ

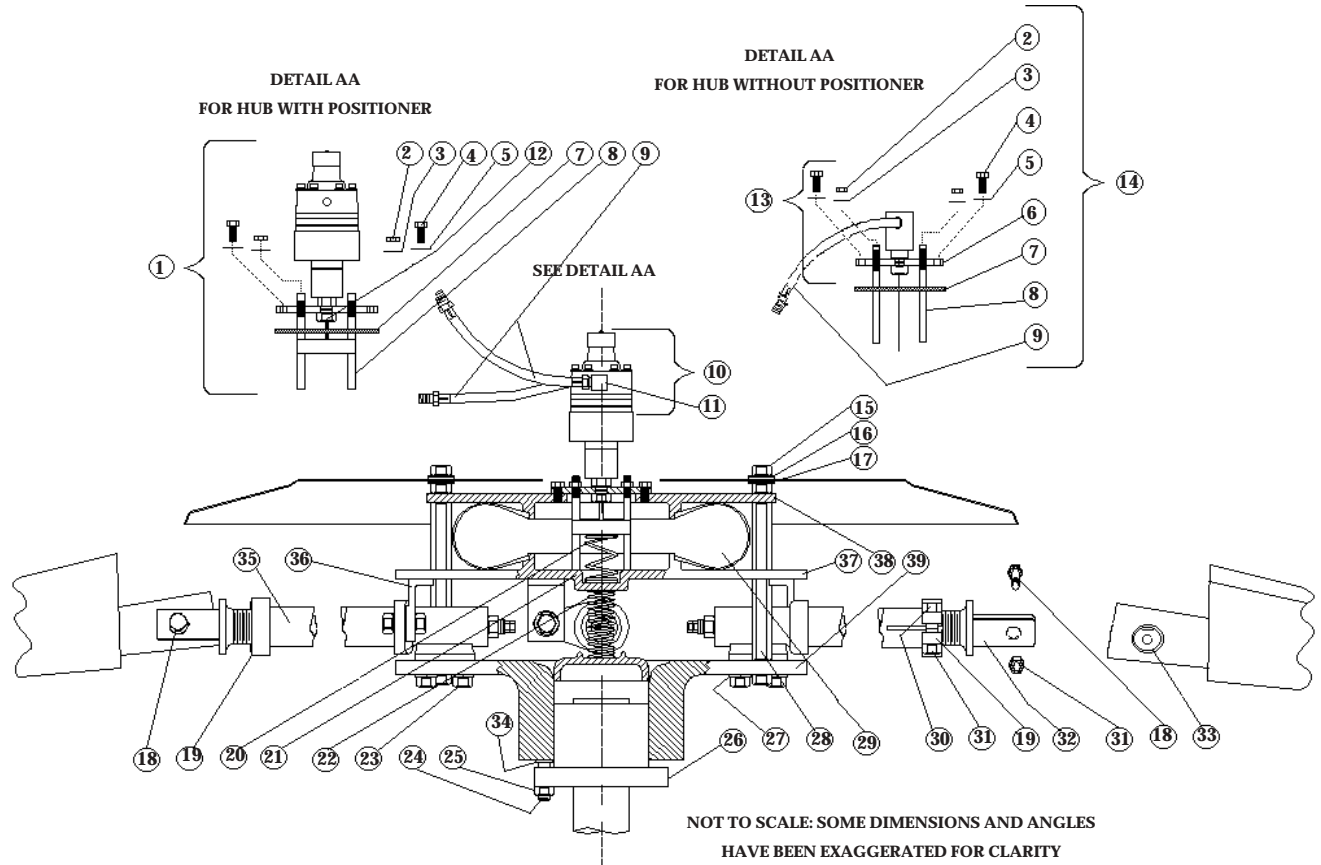

DWG. NO.	SHOP PART NO.	DESCRIPTION
1	2624	CSP UNION ASSEMBLY (WITH POSITIONER)
2	1625	10MM STAINLESS STEEL NUT (3)
3	733	3/8" SEALED WASHER (3)
4	771	10 MM X 30 MM STAINLESS STEEL BOLT (6)
5	179	3/8" FIBER WASHER (6)
6	162	UNION PLATE
7	163	UNION PLATE GASKET
8	159	STAINLESS STEEL STOP STUD (3)
9	257	12" STANDARD STAINLESS STEEL AIR HOSE ASSEMBLY WITH 1/4" NPT EXTERNAL THREADS BOTH ENDS
10	21	POSITIONER
11	210	1/4" BRASS STREET ELL
12	344	5/8-18 LH LOCKNUT
13	264	CS ROTARY UNION
14	186	CS UNION ASSEMBLY WITH HARDWARE
15	1532	18 MM ALUMINUM HEX NUT
16	164	3/4" ALUMINUM FLAT WASHER
17	52	5/8" RESILIENT WASHER
18	168	16 MM X 108 MM ALUMINUM CLEVIS/BLADE BOLT
19	644	SMALL CLEVIS CLAMP
20		RANGESPRING

DWG. NO.	SHOP PART NO.	DESCRIPTION
21		RETURN SPRING SHIM
22		RETURN SPRING
23	1616	10 MM X 45 MM ALUMINUM ANCHOR TEE BOLT (4/BLADE)
24	1568	16MM S STUD FOR QDJ BUSHING (3)
25	1559	16MM S NUT FOR QDJ BUSHING (3)
26		QDJ TYPE BUSHING
27	162	5/8. ALUMINUM LOCK WASHER (4/BLADE)
28	1630	18MM X 302MM ALUMINUM HUB STUD
29	16	DIAPHRAGM ACTUATOR
30	167	16 MM X 70 MM ALUMINUM BOLT (FOR CLEV 18 CLAMP)
31	169	16 MM ALUMINUM NUT
32	2262	CLEVIS
33	637	SMALL MOUNT (1.436")
	989	LARGE MOUNT (1.744")
34		BUSHING STUD WASHER
36		HUB TUBE ASSEMBLY WITH HARDWARE
36		PISTON STRUT ASSEMBLY WITH HARDWARE
37		PISTON PLATE
38		CYLINDER PLATE
39		HUB PLATE

## 6.3 MANUAL FANS

(EXCEPT SERIES 19)

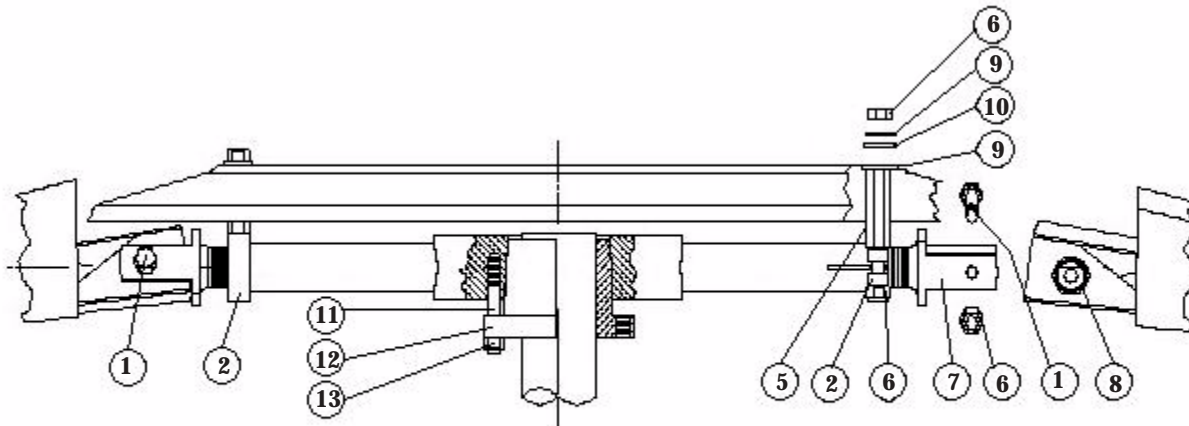

QD BUSHING = TYPE B

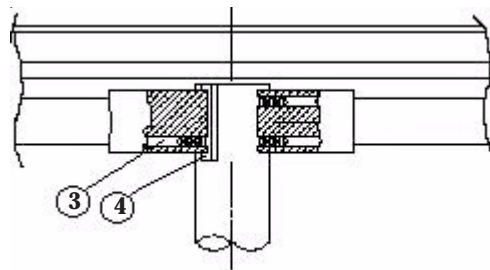

NOT TO SCALE: SOME DIMENSIONS AND ANGLES  
HAVE BEEN EXAGGERATED FOR CLARITY

STRAINGHT BORE HUB - TYPE A

DWG. NO.	SHOP PART NO.	DESCRIPTION	DWG. NO.	SHOP PART NO.	DESCRIPTION
1	168	16 MM X 108 MM ALUMINUM CLEVIS/ BLADE BOLT	11	1345	10MM STAINLESS STEEL STUD FOR QDSF BUSHING(3)
2	644	SMALL CLEVIS CLAMP		1347	12 MM STAINLESS STEEL STUD FOR QDE BUSHING(3)
3	166	12 MM SET SCREW		1558	16MM STAINLESS STEEL STUD FOR QDJ BUSHING(3)
4		KEY	12		QDSF, QDE OR QDJ TYPE BUSHING
5	608	CLAMP STUD	13	1346	10MM STAINLESS STEEL NUT FOR QDSF BUSHING(3)
6	169	16 MM ALUMINUM NUT		1348	12 MM STAINLESS STEEL NUT FOR QDE BUSHING(3)
7	2252	CLEVIS		1559	16MM STAINLESS STEEL NUT FOR QDJ BUSHING(3)
8	637	SMALL MOUNT (1.435")			
9	989	LARGE MOUNT (1.744")			
10	151	5/8" ALUMINUM FLAT WASHER			
	52	5/8" RESILIENT WASHER			

## 6.4 SERIES 19 PARTS LIST

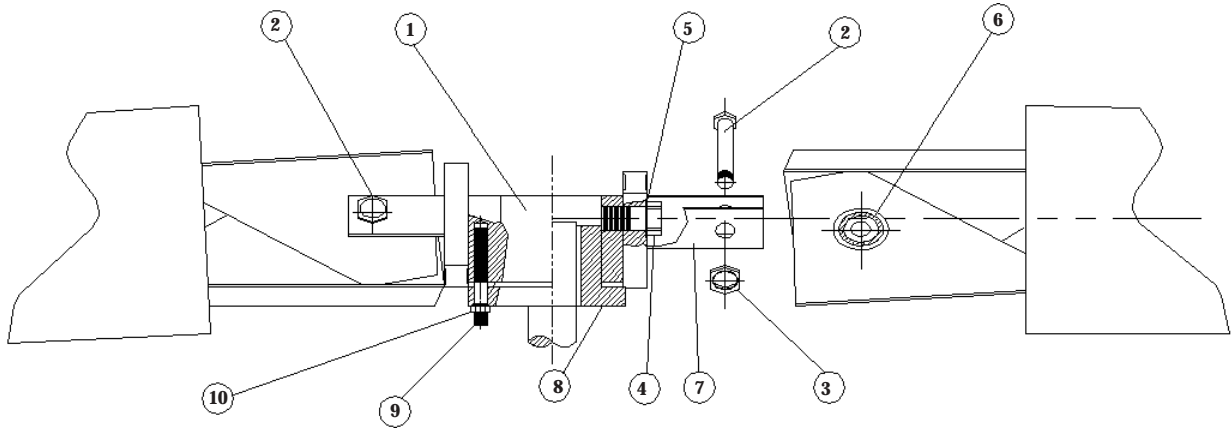

DWG. NO.	SHOP PART NO.	DESCRIPTION
1	898	3-BLADE HUB
	899	4-BLADE HUB
2	168	CLEVIS BLADE BOLT
3	169	CLEVIS BLADE NUT
4	905	CLEVIS HUB BOLT
5	908	LOCKING CLIP

DWG. NO.	SHOP PART NO.	DESCRIPTION
6	637	SMALL MOUNT (1.435")
7	904	CLEVIS (2-1/4")
8		QDSF TYPE BUSHING
9	1345	10MM STAINLESS STUD (3)
10	1346	10MM STAINLESS NUT (3)